



PARATECH

®

Made in the USA and Used Worldwide.

Timeline

- 

1962 WORLD'S FAMOUS PRY AXE INTRODUCED
- 

1965 THE HOOLIGAN TOOL, THE WORLD'S FIRST PRODUCTION "HALLIGAN" TYPE FORCIBLE TOOL IS INTRODUCED
- 

1976 MAXIFORCE® AIR LIFTING BAGS INTRODUCED TO THE UNITED STATES FIRE RESCUE SERVICE
- 

1979 PARATECH BECOMES THE FIRST U.S. MANUFACTURER OF A MOLDED, HIGH PRESSURE AIR LIFTING BAG
- 

1981 THE P-10 TRUCK MADE BY PARATECH FOR THE U.S.A. AIR FORCE STATIONED IN SOUTH KOREA
- 

1983 PARATECH INTRODUCES THE WORLD'S FIRST KEVLAR® REINFORCED AIR LIFTING BAGS UNDER ITS MAXIFORCE® TRADEMARK
- 

1984 PARATECH INTRODUCES THE AIRGUN 40 PNEUMATIC IMPACT TOOL
- 

1985 U.S. NAVY PURCHASES 500 AIRGUN 40S FOR SHIPBOARD FIREFIGHTING
- 

1992 RESCUE STRUTS, THE FIRST SELF-LOCKING COLLAPSE SUPPORT SYSTEMS IN THE WORLD ARE INTRODUCED
- 

1993 FIRST VEHICLE STABILIZATION (VSK) KIT CREATED
- 

1994 NORTHRIDGE, CA EARTHQUAKE: LOS ANGELES CITY & COUNTY RESCUE TEAMS USE MAXIFORCE® LIFTING BAGS, RESCUE STRUTS, PRT KITS AND PRY-AXES FOR RESCUE
- 

1995 KOBE, JAPAN EARTHQUAKE: MAXIFORCE® LIFTING BAGS, RESCUE STRUTS, PRT KITS AND PRY-AXES USED FOR RESCUE
- 

1998 PARATECH ACHIEVES ISO 9001 CERTIFICATION
- 

1999 ISTANBUL, TURKEY EARTHQUAKE: RESCUE STRUTS & MAXIFORCE® LIFTING BAGS BECOME A VITAL PART OF EARTHQUAKE PREPAREDNESS
- 

2000 LONGSHORE STRUTS DESIGNED & DEVELOPED FOR HIGH ANGLE COLLAPSE RESCUE
- 

2002 THE BUSTER TOOL IS DESIGNED TO MEET AND EXCEED FAA REGULATIONS FOR CRASH AXES
- 

2002 PARATECH EU IS ESTABLISHED IN DENMARK IN ORDER TO CREATE A STRONGER PRESENCE IN EUROPE
- 

2003 PARATECH RESCUE SUPPORT SYSTEMS ARE ADAPTED BY FEMA AS A STANDARD
- 

2004 UNITED KINGDOM STANDARDIZES ON PARATECH RESCUE STRUTS FOR THEIR COLLAPSE AND US&R OPERATIONS
- 

2005 THE SHORING HAMMER IS INTRODUCED AND USED THROUGHOUT NEW ORLEANS IN THE WAKE OF HURRICANE KATRINA
- 

2006 THE SMT™ (SPECIAL MISSION TENDER) IS INTRODUCED FOR QUICK AND EASY DEPLOYMENT AND PURCHASE OF PARATECH EQUIPMENT
- 

2007 THE WALER SYSTEM IS DEVELOPED
- 

2007 SINGAPORE CIVIL DEFENSE RESPONDS TO CHINA EARTHQUAKE WITH PARATECH EQUIPMENT
- 

2008 THE MULTI BASE IS DESIGNED FOR RESCUE SUPPORT SYSTEMS
- 

2009 PARATECH EQUIPMENT DEPLOYED TO L'AQUILA, ITALY EARTHQUAKE
- 

2010 PARATECH EQUIPMENT DEPLOYED TO HAITI EARTHQUAKE
- 

2010 THE STRONGEST 'ALL IN ONE' VEHICLE STABILIZER, THE TVS, (TWISTLOCK VEHICLE STABILIZER) IS INTRODUCED
- 

2012 ABSOLUTE RAKER—FIRST ALL MECHANICAL RAKER SHORE INTRODUCED
- 

2013 HYDRAULIC-FUSION-STRUT (HFS) PARATECH'S FIRST HYDRAULIC RESCUE STRUT UNVEILED
- 

2014 DAMAGE CONTROL SYSTEMS (DCS) PARATECH DCS INSTALLED ON SWEDISH NAVY SHIPS
- 

2014 PARATECH INTRODUCES MAXIFORCE® G2 AIR LIFTING BAGS
- 

2014 THE TITAN CRASH AXE IS CREATED BY PARATECH, WITH INPUT FROM THE AIR FORCE'S PARARESCUEMEN
- 

2015 THE MULTIFORCE® AIR LIFTING BAG IS INTRODUCED
- 

2016 THE VSK CONTROLLER IS INTRODUCED
- 

2016 MULTIFORCE POSITIONING LIGHTS ARE INTRODUCED
- 

2017 THE ACMETHREAD STRUT DRIVER RETRO FIT KIT IS INTRODUCED
- 

2018 PARATECH INTRODUCES THE ACMETHREAD STRUT DRIVER
- 

2019 THE G3 DEADMAN CONTROLLERS AND VENTED COUPLINGS ARE INTRODUCED
- 

2020 G3 PRESET REGULATOR INTRODUCED
- 

2022 RESCUE GUARDIAN IS INTRODUCED

PARATECH

For more than 50 years, Paratech has been combining innovative design with cutting edge technology to provide the highest quality and most user-friendly tools available for rescue and beyond. From the world's most advanced collapse support solutions to some of the world's strongest forcible entry tools, Paratech makes technical rescue operations simpler, safer and more productive.

Our product lines are comprised of Rescue Support Systems, MAXIFORCE[®] Air Lifting Bags, The MULTIFORCE[®] Air Lifting Bag, Powered Impact Tools, Forcible Entry Tools, Rescue Air Cushions, and the ultimate collection of essential Paratech products...the SMT[™]...

Special Mission Tender equipped specifically for either urban search and rescue or trench rescue, both are loaded with all of the necessary Paratech tools needed for technical rescue.

Paratech products are extensively used by fire departments worldwide including, but not limited to: all major U.S. cities, Copenhagen, Tokyo, London, Lyon, Madrid, Singapore and Istanbul. In addition, they have been selected by disaster agencies in the United States, Denmark, Japan, United Kingdom and Turkey as the standard for their rescue teams and technical rescue caches.



Vehicle Stabilization Kits

Vehicle Stabilization Kit

Paratech Vehicle Stabilization Kits have the strength and flexibility to handle any size vehicle anytime, anywhere. This includes sub compact cars, buses, cement trucks and even train locomotives. Additionally, these components provide the extra value of being completely interchangeable with your other Paratech equipment for building collapse and trench rescue scenarios. They are strong, sturdy and reliable. Paratech systems are the easiest to use and the strongest VSKs on the market today.

VSK Comparison

	Supporter	Standard	Highway	Interstate
Max Load	10,000lb / 4,536kg	40,000lb / 18,143kg	80,000lb / 36,287kg	120,000lb / 54,431 kg
# of AcmeThread Struts	0	2	4	0
# of LongShore Struts	0	0	0	6
# of Extensions	1	4	6	6
# of Bases	1	4	8	18
# of Ratchet Belts	1 (Attached)	4	4	6

With the highest industry safety standard, Paratech's VSK can hold 10,000lb / 4,536kg up to 120,000lb / 54,431kg. Paratech vehicle stabilization kits have the strength & flexibility to handle any size vehicle anytime, anywhere.



Comes with
Coupling Plug



VSK V2 Controller

Safely use compressed air to extend struts! This innovative controller is capable of extending the heaviest combination of struts and extensions with a simple on / off control. Its low 29 PSI / 2Bar pressure reduction and unique automatic vent relief feature, eliminates the fear of over pressurizing in the event of a load shift, ensuring a secure and steady strut extension. Ideal for safely chasing stabilization struts while performing a lift.

NOW WITH TWO AIR OUTLETS!

Net Weight: 2.4 lbs 1.0 kg

Part No. 22-796V02

Coupling Plug

Coupling Plug

Use to plug an open coupling.
Part Number 22-890715

Plug Tether

Tether the coupling plug to your controller.
Part N. 22-890717



Supporter X2- All-In-One Vehicle Stabilizer

**The 'ALL IN ONE' Vehicle Stabilizer!
Stronger, Faster, Safer!**

When you need to stabilize a vehicle accident scene quickly, there is nothing faster or stronger. With the TwistLock Collar all you need to do is **TWIST, EXTEND, LOCK** and the SUPPORTER can stabilize 10,000 lb / 4,536 kg with a 2:1 safety factor at ANY height.

**Maximum load up to 10,000 lb / 4,536 kg
with a 2:1 safety factor**

- Easy Extra Extension Ability
- Weight: 35.0 lb / 15.9 kg
- Collapsed, Base on Ground
40 in / 101.6 cm
- Extended, Base on Ground
65.4 in / 166.1 cm
- Extended with Extension
95.4 in / 242.3 cm

Kit Part No.	Net Weight: lb	kg
22-797E12E SUPPORTER X2	35.0	15.9

**Quick Super
Extension to
95.4 in / 242.3 cm**



**Spike Base
Positive Grip
Shackle Hole
Angle Indicator
Replaceable Spikes
Integrated V &
Cone Base**

**Quick
Extension To
70.0 in / 177.8 cm**

**Twist-Lock
Collar**

**Auto-Rewind
Belt**

**Integrated
Ratchet Belt**

**90° Base
Folds Flat For
Easy Storage**

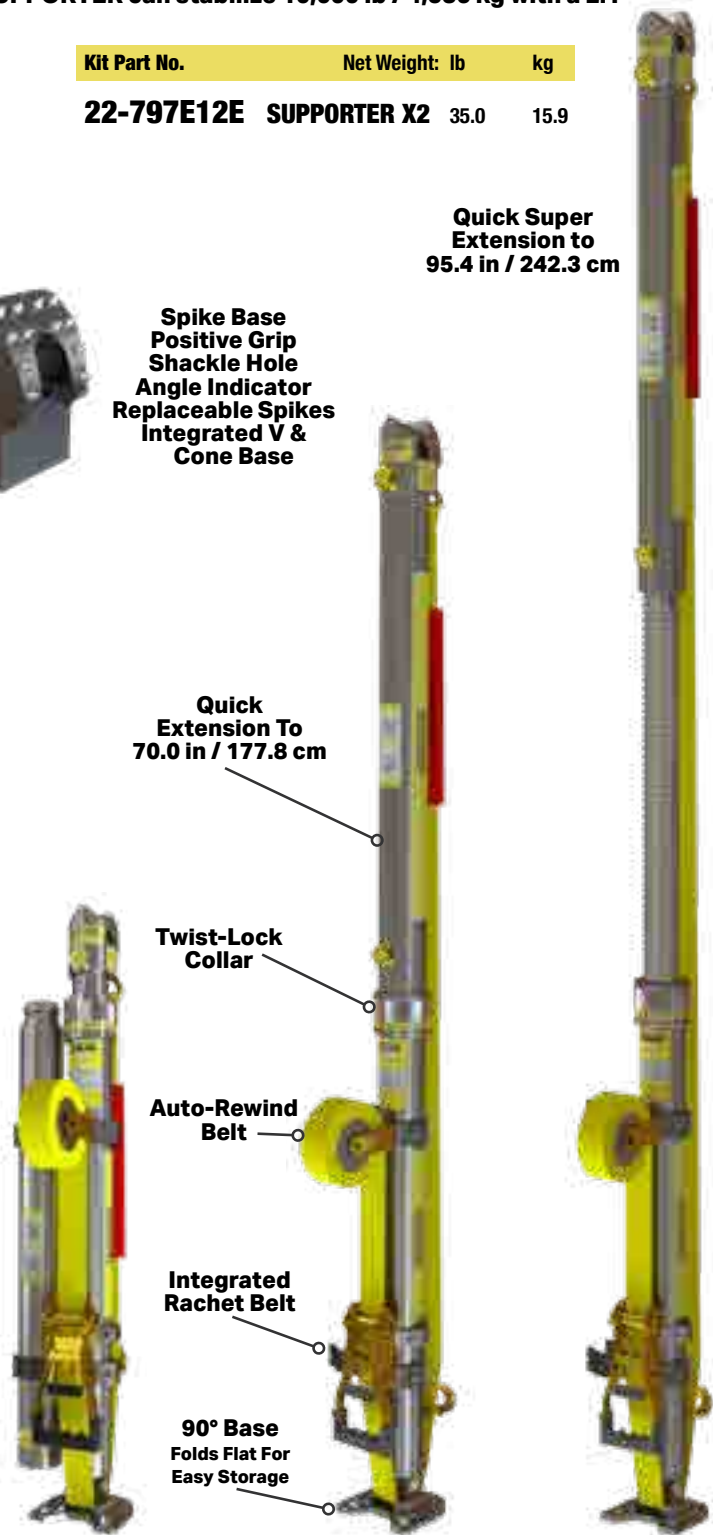

Vehicle Stabilization Kits

VSK Base Kits

Bases integrated with ratchet belt and anchor ring, ready for rapid deployment, making vehicle stabilization quicker & easier.

VSK Base 6 Kit Part No.	Net Weight: lb	kg
22-796303	25.9	11.7

Part No.	Description	Quantity
22-796331	VSK Base 6	1
22-797042E	Adjustable Carrying Handle	1
22-796161	Tie-Down Keys w/J Hook	1

Product Features:

- Fast and Easy to Deploy
- Available with Small or Large Size Base Foot
- Integrated Anchor Ring for Multiple Ratchet Belt Usage
- Built in Ratchet Keeps Hot Zone Free Of Tripping Hazard from Unused Belt
- Compatible with All Of Paratech's Acmethread and Lockstroke Rescue Support System Components

VSK Base 12 Kit Part No.	Net Weight: lb	kg
22-796309	30.9	14.0

Part No.	Description	Quantity
22-796308	VSK Base 12	1
22-797042E	Adjustable Carrying Handle	1
22-796161	Tie-Down Keys w/J Hook	1



1 - Adjustable Carrying Handle
22-797042E

1 - Tie Down Keys with J Hook
22-796161



1 - Adjustable Carrying Handle
22-797042E

1 - Tie Down Keys with J Hook
22-796161

**Load Capacity of
20,000 Lbs. / 9,071.8 Kg
with a 4:1 Safety Factor.**

Standard VSK

Paratech's flagship kit and the "standard" when addressing your stabilization needs. This kit covers everything from small vehicles to large commercial/municipal vehicles.

**Maximum load up to 40,000 lb / 18,144 kg
with a 4:1 safety factor**

Kit Part No.	Net Weight: lb	kg
22-796850	97.3	44.2

Part No.	Description	Quantity
22-796200	AcmeThread Strut 25-36 in / 64-91 cm	2
22-796012	Strut Extension 12 in / 30 cm	2
22-796024	Strut Extension 24 in / 61 cm	2
22-796025	Multi-Base	2
22-796180C	Hinged Base w/Anchor Ring 12 in / 30 cm	2
22-890553	Ratchet Belt w/Finger Hook 27 ft / 8.2 m	4
22-796161	Tie Down Keys w/J Hook	2



2 - Strut Extensions 12 in / 30 cm 22-796012

2 - Strut Extension 24 in / 61 cm 22-796024



2 - AcmeThread Struts 25-36 in / 64-91 cm 22-796200



4 - Ratchet Belt with Finger Hook 27 ft / 8.2 m
22-890553



2 - Tie Down Keys with J Hook
22-796161



2 - Hinged Base with Anchor Ring 12 in / 30 cm
22-796180C



2 - Multi-Base
22-796025



Heavy Vehicle Extrication Kit

The most comprehensive heavy lifting kit available, utilizing the strength of HydraFusion Struts, lifting height and power of the MULTIFORCE in the Rapid Extrication Kit, as well as the environmentally friendly sturdiness of recycled plastic cribbing PLUS much more. With this Kit you can lift and stabilize any SIZE vehicle on the road. All packed up in 4 convenient, mobile carrying cases.

22-88HVEK Heavy Vehicle Extrication Kit
 22-88HVEKD Heavy Vehicle Extrication Kit DIN
 Weight 1,259.1 lbs/ 571.1 kg

Part No.	Description	Quantity
22-79HA10K	HydraFusion 10 Kit	2
22-796035	Extension Converter	2
22-796180C	Hinged Base Plate w/ Anchor Ring 12 in / 30 cm	6
22-88DREK	Rapid Extrication Kit	1
22-796720	LongShore Strut 304 36-50 in / 91-127 cm	2
22-796730	LongShore Strut 406 48-73 in / 122-185 cm	2
22-796360	LongShore Strut 610 72-116 in / 183-295 cm	2
22-796342	LongShore 235 Extension 24 in / 61 cm	2
22-796356	LongShore 435 Extension 48 in / 122 cm	2
22-796376	LongShore 635 Extension 67 in / 170 cm	2
22-000680	SPF Hooligan	1
22-796090	V Base	4
22-796270	Contour Base	4
22-796025	Multi-Base	4
22-890015	Non Slip Neoprene Pad	2
22-796P14	Double Headed Picket 40 in / 106cm	4
22-796C1H	Chain 20 ft / 6.1 m x 3/8 in, grade 100	2
22-890553	Ratchet Belt w/Finger Hook 27 ft / 8.2 m	6
22-796161	Tie Down Keys w/J Hook	4
22-796979	Chain Binder	2
22-88C00K	Cribbing Kit	1
22-796V02	VSK Controller	1



- Stabilize Everything from Small Vehicles, Large Commercial/ Municipal Vehicles, and Fully Loaded Tractor Trailers to Trains
- Ease of Use: No Pins, No Cables
- Extremely Safe and Secure: Paratech Struts Always Default to Locked Position
- Includes 4 Carrying Cases For Convenient Storage of Smaller Parts, Providing a Fast And Organized Way To Bring Everything You Need To The Scene
- Custom cut outs in cases to securely hold equipment in place
- Consistency and Organized Placement Of Components After Use
- Cases are Labeled with Contents



Rapid Extrication Kit

Combining the speed of Paratech's MULTIFORCE Air Lifting Bag with the flexibility of our Standard VSK, the Rapid Extrication Kit gets vehicles lifted and stabilized quicker than any other.

22-88DREK Rapid Extrication Kit
 22-88DREDK Rapid Extrication Kit DIN
 Weight 190.2 lb / 86.3 kg

Part No.	Description	Quantity
22-88D025K	Remote Placement MULTIFORCE Bag Kit	1
22-796200	AcmeThread Strut 25-36 in / 64-91 cm	2
22-796012	Strut Extension 12 in / 30 cm	2
22-796024	Strut Extension 24 in / 61 cm	2
22-796025	Multi-Base	2
22-796180C	Hinged Base 12 w/Anchor Ring	2
22-890553	Ratchet Belt 27' WLL 3300 lbs	4
22-796161	Tie Down Keys w/J Hook	2



Vehicle Stabilization Kits

Highway VSK

Doubling the capacity of the Standard VSK, this kit is designed for multiple vehicles, longer reach and heavier weights such as a fully loaded tractor trailer.

Maximum load up to 80,000 lb / 36,287 kg with a 4:1 safety factor

 2 - Strut Extensions 12 in / 30 cm 22-796012

 2 - Strut Extensions 24 in / 61 cm 22-796024

 2 - Strut Extensions 36 in / 91 cm 22-796036

 2 - AcmeThread Struts 25-36 in / 64-91 cm 22-796200

 2 - AcmeThread Struts 37-58 in / 94-147 cm 22-796202

Kit Part No.	Net Weight: lb	kg
22-796852	167.5	76.0

Part No.	Description	Quantity
22-796200	AcmeThread Strut 25-36 in / 64-91 cm	2
22-796202	AcmeThread Strut 37-58 in / 94-147 cm	2
22-796012	Strut Extension 12 in / 30 cm	2
22-796024	Strut Extension 24 in / 61 cm	2
22-796036	Strut Extension 36 in / 91 cm	2
22-796025	Multi-Base	4
22-796180C	Hinged Base w/Anchor Ring 12 in / 30 cm	4
22-890553	Ratchet Belt w/Finger Hook 27 ft / 8.2 m	4
22-796161	Tie Down Keys w/J Hook	4



Vehicle Stabilization Kits

Interstate/Motorway VSK

The ultimate vehicle stabilization kit. There is no vehicle on the road, runway or track that this kit cannot stabilize. When your vehicular rescue needs the strongest system available, look no further.

Maximum load up to 120,000 lb / 54431 kg with a 4:1 safety factor



3 - LongShore Extension 235 24 in / 61 cm 22-796342



3 - LongShore Extension 435 48 in / 122 cm 22-796356



2 - LongShore Strut 304 36-50 in / 91-127 cm 22-796720



2 - LongShore Strut 406 48-73 in / 119-185 cm 22-796730



2 - LongShore Strut 610 72-116 in / 183-295 cm 22-796360



4 - Tie Down Keys with J Hook 22-796161



6 - Ratchet Belt with Finger Hook 27 ft / 8.2 m 22-890553



4 - Contour Base
22-796270



4 - V Base
22-796090



4 - Multi-Base
22-796025

Kit Part No.	Net Weight: lb	kg
22-796855	438.2	198.0

Part No.	Description	Quantity
22-796720	LongShore Strut 304 36-50 in / 91-127 cm	2
22-796730	LongShore Strut 406 48-73 in / 122-185 cm	2
22-796360	LongShore Strut 610 72-116 in / 183-295 cm	2
22-796342	LongShore 235 Extension 24 in / 61 cm	3
22-796356	LongShore 435 Extension 48 in / 122 cm	3
22-796090	V Base	4
22-796270	Contour Base	4
22-796025	Multi-Base	4
22-796180C	Hinged Base Plate w/ Anchor Ring 12 in / 30 cm	6
22-796C1H	Chain 20 ft / 6.1 m x 3/8 in, grade 100	2
22-890553	Ratchet Belt w/Finger Hook 27 ft / 8.2 m	6
22-796161	Tie Down Keys w/J Hook	4
22-890015	Non Slip Neoprene Pad	2



6 - Hinged Base with Anchor Ring 12 in / 30 cm 22-796180C



2 - Non Slip Neoprene Pad
22-890015



2 - Chain 20 ft / 6.1 m x 3/8 in, grade 100 22-796C1H



Available in five languages.



CERTIFICATE NO.
ISO9001:2008

**We take our job
seriously because
we know your job
is often a matter
of life or death.**



A division of PT Hydraulics Australia PTY LTD
19 Ricketts Rd Mt Waverley VIC 3149
ph: 03 9562 8800 e: rescue@ptha.com.au
www.ptrescue.com.au

www.paratech.com